



JOB NAME:	CONTRACTOR:
JOB LOCATION:	APPROVAL:
ENGINEER:	CONTRACTOR P.O.:
APPROVAL:	REPRESENTATIVE:

8E076-00*

720016 2-WAY STAINLESS STEEL, ANSI 150 FLANGED, WAFER STYLE, FULL PORT BALL VALVE WITH VALBIA ELECTRIC ACTUATOR AND BRACKET

SIZES 1/2" TO 6"

*001	12V AC/DC	*002	24V AC/DC	*003	100-240V AC
01	BATTERY BACKUP	*02*	POSITIONER	*04*	BATTERY BACKUP W POSITIONER

SPECIFICATIONS

The Bonomi M8E076 series electric package features the 720016-stainless steel, short pattern, wafer full port, ANSI 150 flanged ball valve, in sizes 1/2"-6".

This space saving valve also meets ANSI 16.34, ANSI 16.5, NACE MR 0175/ISO 15156 and NACE MR 0103. It has RTFE seats, and a combination PTFE and Viton dual stem packing design.

The Valbia VB series actuator housing is made from a high impact resistant technopolymer, and standardly features dual motors, two extra limit switches, a heater & thermostat, a torque limiter, dual ISO patterns, female star drive, position indicator, PG11 connections, and a 75% duty cycle motor. The actuator is also NEMA 4,4X rated. Options include positioning boards, battery backups, or a combination of the two.

ACTUATOR FEATURES

- NEMA 4, 4X IP67 Housing
- 12V/24V AC/DC and 100-240V AC
- Models Available
- ISO 5211 dual patterns
- VB015 -12/24V AC - 50% Duty Cycle
- VB030-VB110 - 12/24V DC and 100-240V AC - 75% Duty Cycle
- High-Strength, Impact Resistant IP67 Technopolymer Housing
- Heater & Thermostat
- Torque Limiter
- Temperature Range -4°F to 131°F
- PG11 Electrical Connection/Optional 1/2" Conduit

VALVE FEATURES

- Stainless Steel, ANSI class 150 flanged
- Full port, sizes 1/2" to 6"
- Temperature range -4°F to 400°F
- Blow-out proof stem
- R.P.T.F.E. seats, packing and thrust washer
- Space saving design
- 100% tested
- TUV T.A. Luft approved
- ANSI B16.34 design
- ISO 5211 mounting pad with double "D" stem

PRESSURE - TEMPERATURE CHART FOR SERIES 720016

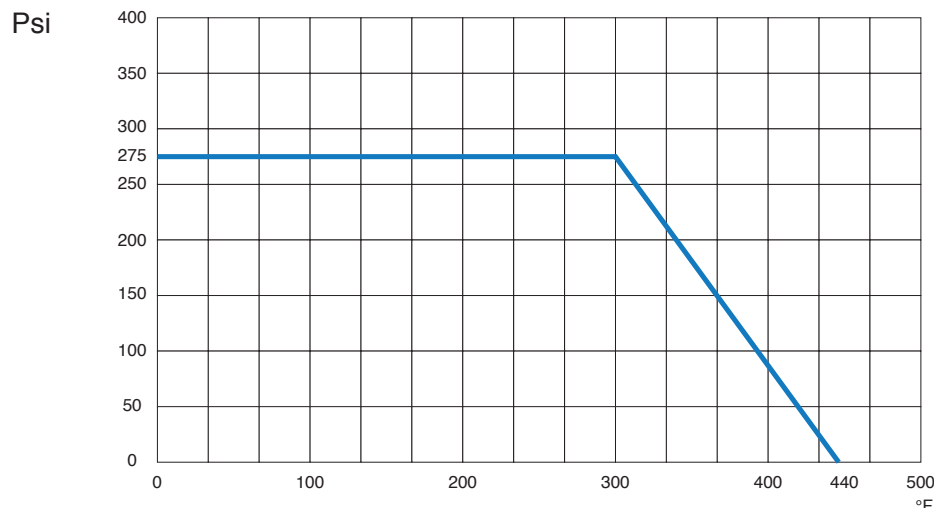

BILL OF MATERIALS FOR 720016

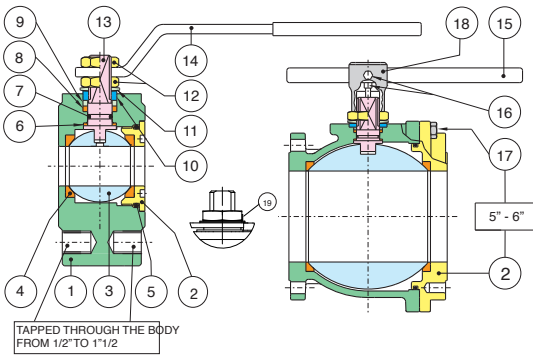

N POS	PART NAME	MATERIAL	N PCS
1	BODY	A479-316/A351 CF8M	1
2	END CONNECTION	A479-316/A351 CF8M	1
3	BALL	A479-316/A351 CF8M	1
4	BALL SEATS	R.P.T.F.E.	2
5	O-RING	FKM (Viton®)	1
6	THRUST WASHER	P.T.F.E.	1
7	RING	FKM (Viton®)	1
8	STEM SEAL	P.T.F.E.	1
9	PACKING GLAND	STEEL	1
10	END STOP	AISI 430 (1/2" - 2") STEEL (2-1/2" - 6")	2 1

N POS	PART NAME	MATERIAL	N PCS
11	SPRING WASHER	STEEL	2
12	NUT	STEEL	2
13	STEM	A479-316	1
14	HANDLE	STEEL	1
15	HANDLE DN 150-200	STEEL	1
16	SCREW	STEEL	2
17	SCREW	STEEL	8-12
18	BODY HANDLE DN150-200	CAST IRON	1
19	UNSCREWING GROWER	A182-F316	1

DIMENSIONS

Size	1/2"	3/4"	1"	1-1/4"	1-1/2"	2"	2-1/2"	3"	4"	6"
A	.500	.750	1.00	1.25	1.50	2.00	2.50	3.00	4.00	6.00
B	10.5	10.9	13.1	13.8	15.7	16.2	17.9	18.6	20.6	22.1
C	8.81	8.97	11.0	11.2	12.9	13.2	14.5	14.9	16.3	17.2
D	4.84	4.84	6.18	6.18	7.28	7.28	8.30	8.30	8.30	8.30
E	6.45	6.45	7.51	7.51	8.46	8.46	9.33	9.33	9.33	9.33
F	1.37	1.57	1.81	2.12	2.51	3.22	4.05	4.80	5.98	7.71
G	3.54	3.93	4.33	5.11	5.51	5.90	6.88	7.48	8.66	9.84
Act.	VB015	VB015	VB030	VB030	VB060	VB060	VB110	VB110	VB190	VB190

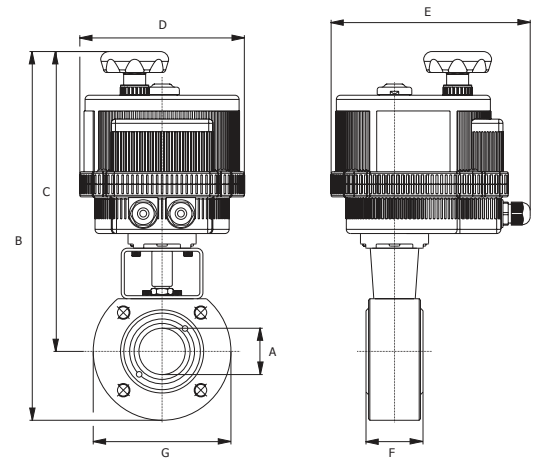

ON/OFF WIRING DIAGRAM - VB015

12V AC/DC, 24V AC/DC & 100-240VAC

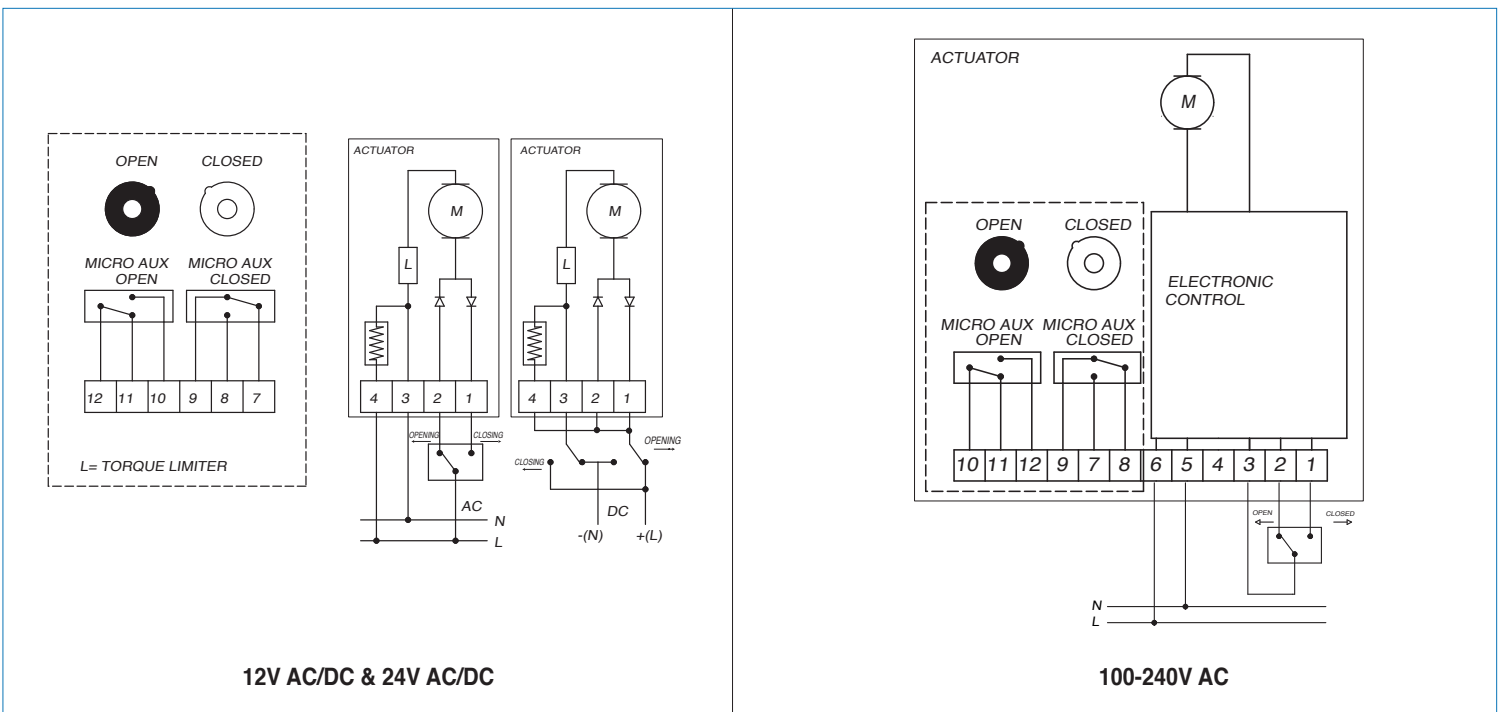

ON/OFF WIRING DIAGRAM - VB030 -VB190

12V AC/DC, 24V AC/DC & 100-240VAC

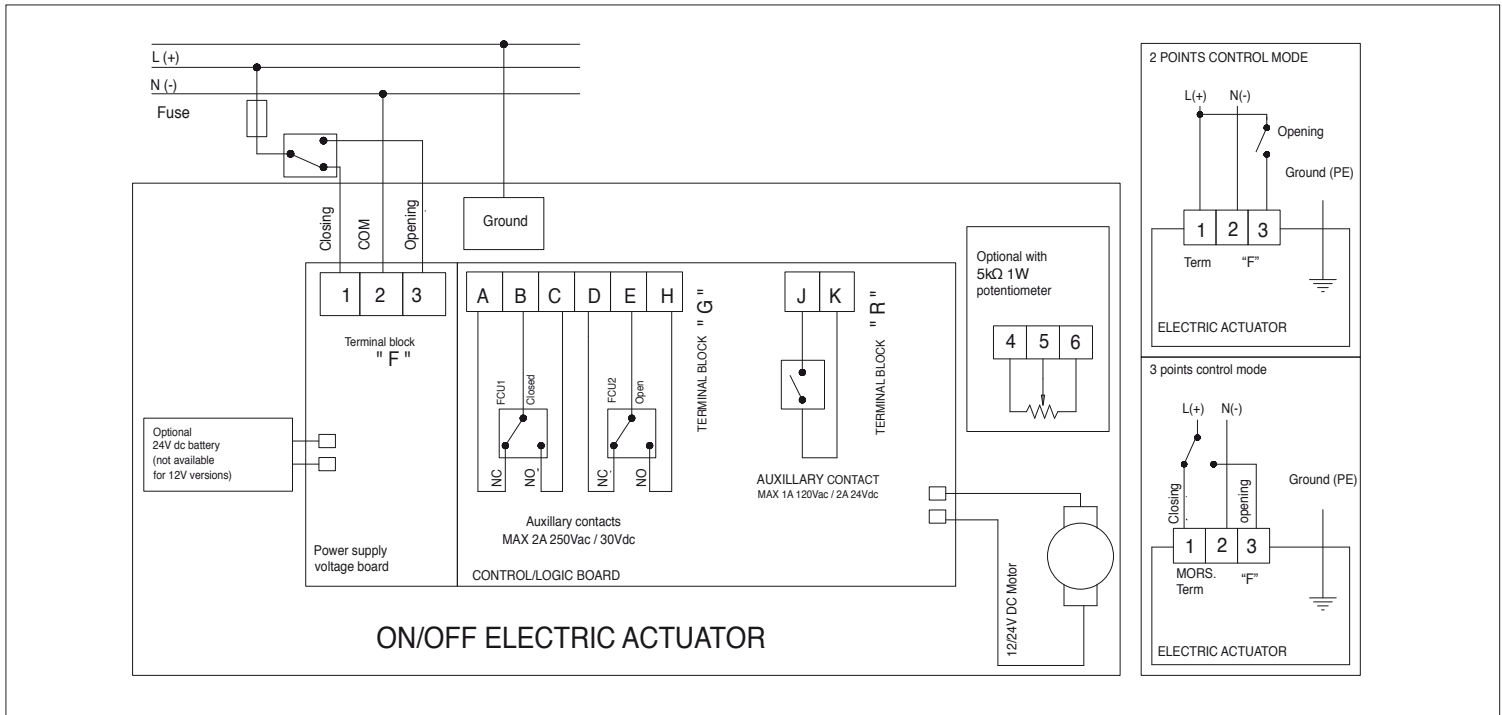

POSITIONER WIRING DIAGRAM - VB030 -VB190

12V AC/DC, 24V AC/DC & 100-240VAC

